

Quick Setup Guide >

External Battery Backup

- A** External Battery Backup x 1
- B** Replaceable Head x 1
- C** Anchor x 2
- D** Screw x 2

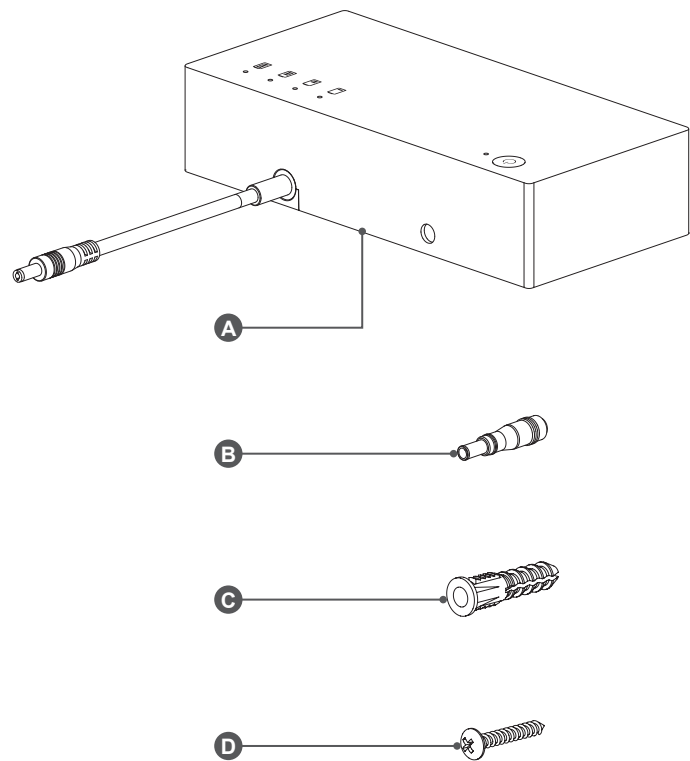

Setting up the External Battery Backup

Please note: Before proceeding with these steps, make sure you have read and understood the user manual for your Business Internet Gateway and power-related instructions to ensure correct and safe operation.

Step 1. Connect the External Battery Backup to your Business Internet Gateway

- a. Insert the cable from the battery (A) into the replaceable head (B).

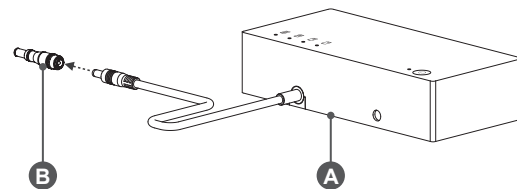

- b. Insert the replaceable head (B) into Verizon Business Internet Gateway.

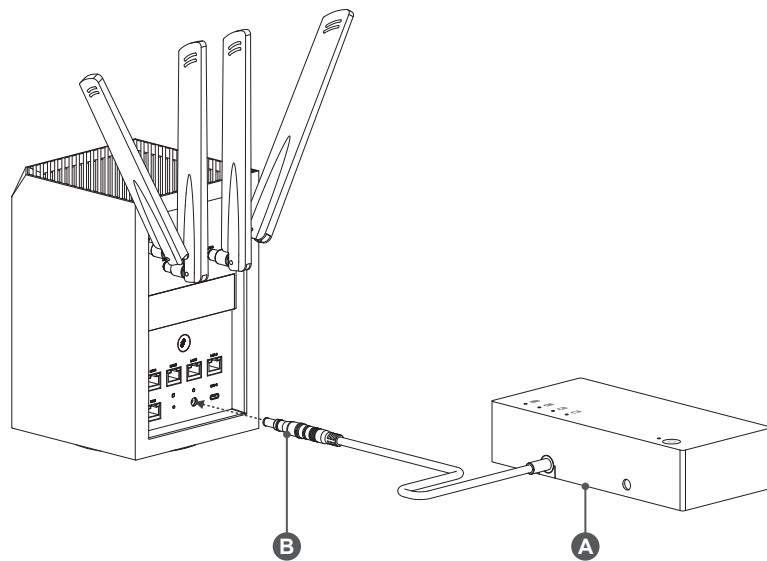

Step 2. Connect to AC Power

- a. Plug the connector of the power supply unit **that you received with the Verizon Business Internet Gateway** into the battery (A) as shown below.

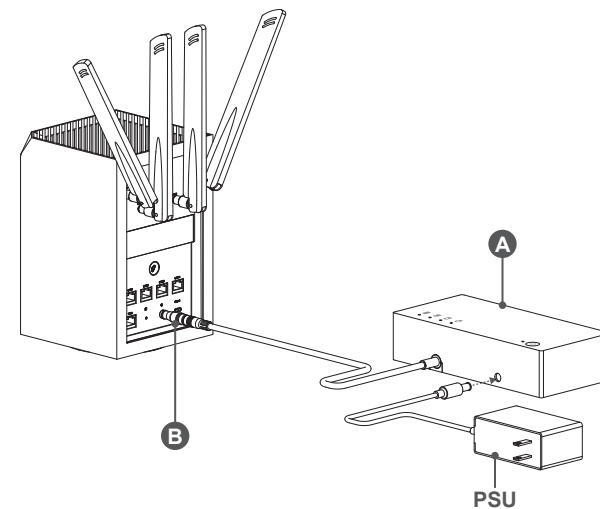

- b. Insert the Power Supply Unit into a Wall outlet

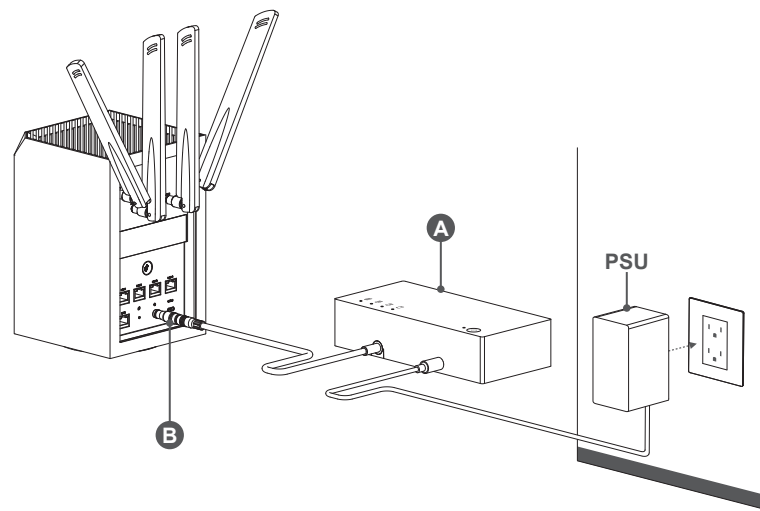

- c. Check all connection points to ensure all connections are fully inserted, avoiding any looseness.

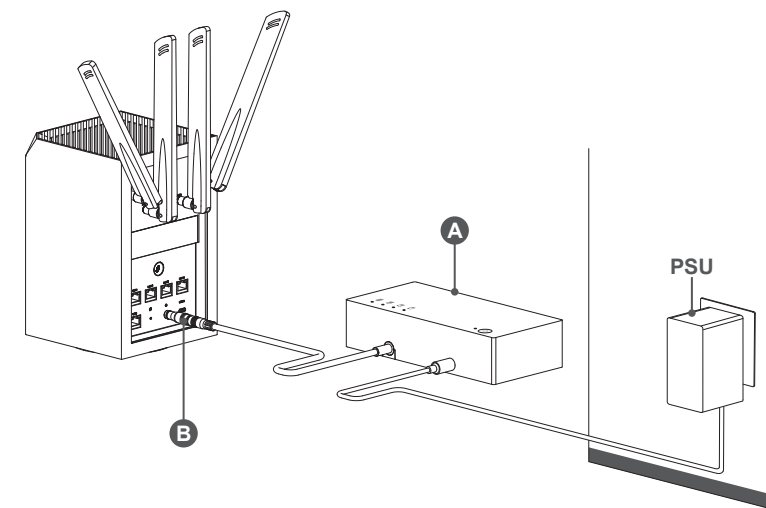

Note 1: For the first time use, please connect the PSU with the External Battery Backup before pressing the wake-up button.

Note 2: Always keep the Battery (A) and PSU at least 1 foot away from the Business Internet Gateway.

- d. The battery will be fully charged **after 20 hrs**

Check Power Level

You can identify the status and remaining power level for from LEDs on top of the External Battery Backup

Status	LED number	Remaining capacity (%)
Battery Charge (Green LED)	LED 1 is blinking	Battery capacity less than 25%
	LED 1 is solid, LED 2 is blinking	Battery capacity 26% ~50%
	LED 1 and 2 are solid, LED 3 is blinking	Battery capacity 51% ~75%
	LED 1, 2, and 3 are solid, LED 4 is blinking	Battery capacity 76% ~100%
	All LEDs are solid	100% capacity
Battery Discharge (Green LED)	LED 1 is solid	Remaining capacity less than 25%
	LED 1 and 2 are solid	Remaining capacity 26%~50%
	LED 1, 2 and 3 are solid	Remaining capacity 51%~75%
	LED 1, 2, 3, and 4 are solid	Remaining capacity 76%~100%
Error (Red LED)	LED 5 display (Red)	Error(OCP,OTP,OVP, charge fail)*
Wake-up Button	Press over 1 seconds	Turns on Battery status check if the battery is not powered or powering any device. It will re-enter sleep mode after 30 seconds to save the battery capacity.
Replace Battery Alarm	LED 5 display (Yellow)	After 24hrs SOH<60%^

When the EXTERNAL BATTERY BACKUP is unable to supply power, the remaining capacity may be too low. It is recommended to recharge this product when it reaches below 25% of capacity.

* For Over Current Protection(OCP), Over Temperature Protection(OTP), and Over Voltage Protection (OVP), refer to the External Battery Backup User Manual for next steps.

^ For State of Health(SOH), refer to the External Battery Backup User Manual for next steps.

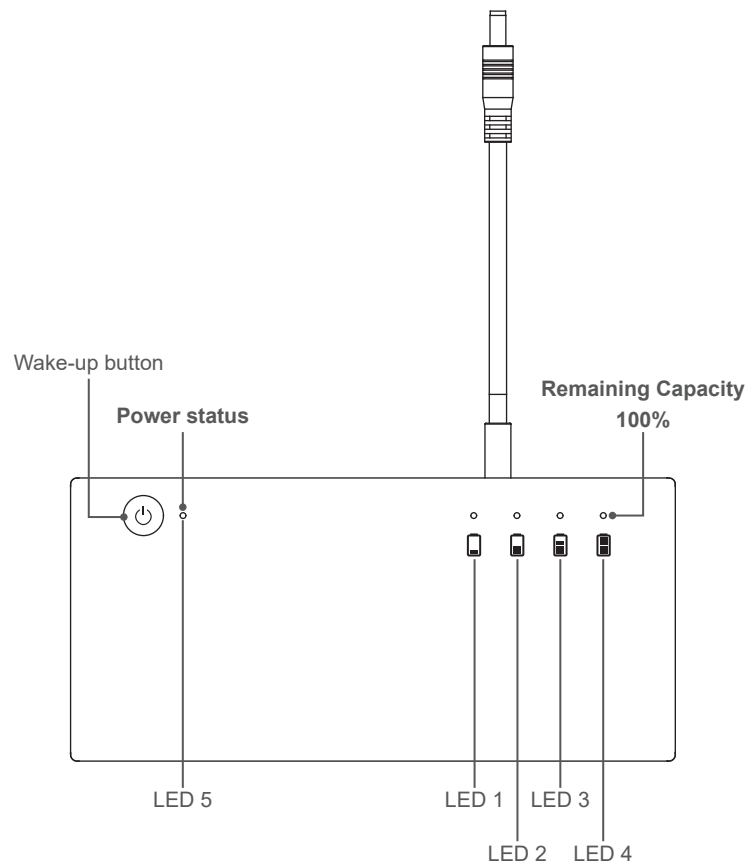

Basic Information

- Rated Capacity: 21Ah / 189Wh
- Input Voltage/Current: DC 12V / 5A
- Output Voltage/Current: DC 9V / 5.5A
- Operating Temperature: 0-40°C (32-104°F)
- Full charging from empty state: 16~20 hrs

Wall Mount Assembly (Optional)

1. Drill the 2 holes and place the two (2) anchors (C) 7.15 Inches apart as illustrated.

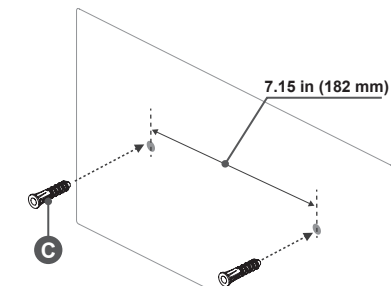

2. Secure the two (2) screws (D) into the wall anchors.

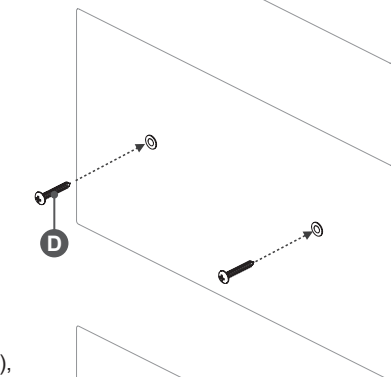

3. Align the holes on back of the battery to the screws on the wall (D), to ensure battery is firmly secured and leveled.

